



STORAGE HEXAGONAL | STORAGE PLASTIC | STORAGE METAL  
INSTANT WATER HEATER | IMMERSION ROD

# DROID - M

Storage Hexagonal Plastic Water Heater

**+ CONTEMPORARY DESIGN + ANTI-CORROSION TANK + 7 YEARS WARRANTY\***



Unique hexagonal design enhances the beauty of a bathroom and utilises optimum space by its compact size.

Hexagon design adds a modern touch to the ambience

Porcoglass coated inner tank protects against rust & corrosion to provide longer life

BEE 5-star rated product provides high energy savings



PORCO GLASS™  
TECHNOLOGY



PRECISE  
TEMPERATURE  
CONTROL



FREE  
FLEXI PIPES\*\*

Capacity : 10 L, 15 L & 25 L  
 Color : White

## Technical dimensions in mm

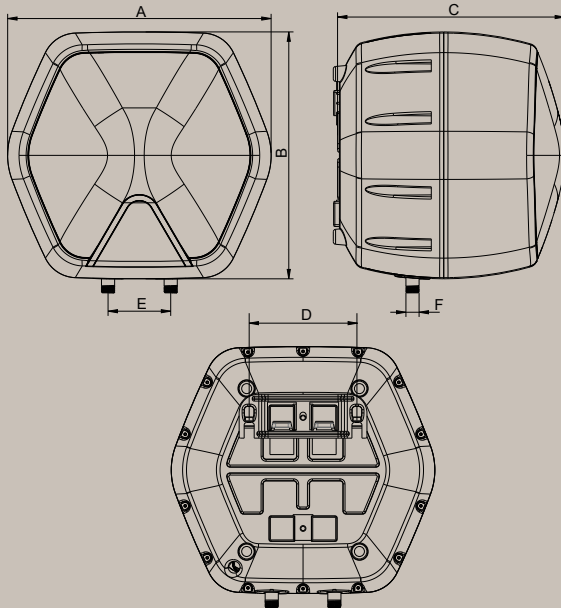

Model	A	B	C	D	E	F
10 L	421 mm	394 mm	302 mm	172 mm	100 mm	12.7 mm (G 1/2)
15 L	421 mm	394 mm	321 mm	172 mm	100 mm	12.7 mm (G 1/2)
25 L	491 mm	461 mm	408 mm	172 mm	100 mm	12.7 mm (G 1/2)

\* Note : All dimension are in mm, dimensions tolerances  $\pm 5$ mm.

\*Warranty on inner tank | \*\*T&C apply



## Features



**Incoloy 800 heating element with enamel coating**  
 Highly resistive to corrosion giving it a longer life



**Heavy duty protective anode**  
 To help increase life of Storage Tank



**Durable inner tank**  
 Single weld line tank made of ultra thick superior quality steel



**Inlet water tube with whirl flow**  
 No immediate direct contact between cold and hot water for faster heating



**Dual safety feature**  
 With automatic thermal cutoff & thermostat



**High density CFC free Polyurethane Foam (PUF) insulation**  
 For energy efficiency and to store hot water for longer duration



**Adjustable Thermostat**  
 All weather temperature setting with maximum temperature of 75 °C



**Multi functional safety valve**  
 For protection against excessive pressure (> 8 bar), ideal for high rise buildings

# GLAZER

Storage Square Plastic Water Heater

**+ CONTEMPORARY DESIGN + ANTI-CORROSION TANK + 7 YEARS WARRANTY\***

**NEW**



Unique square design enhances the beauty of a bathroom and utilises optimum space by its compact size.

Square design adds a modern touch to the ambience

Porcoglass coated inner tank protects against rust & corrosion to provide longer life

BEE 5-star rated product provides high energy savings



PORCO GLASS™  
TECHNOLOGY



PRECISE  
TEMPERATURE  
CONTROL



FREE  
FLEXI PIPES\*\*

Capacity : 10 L, 15 L & 25 L  
 Color : White & Ivory

## Technical dimensions in mm

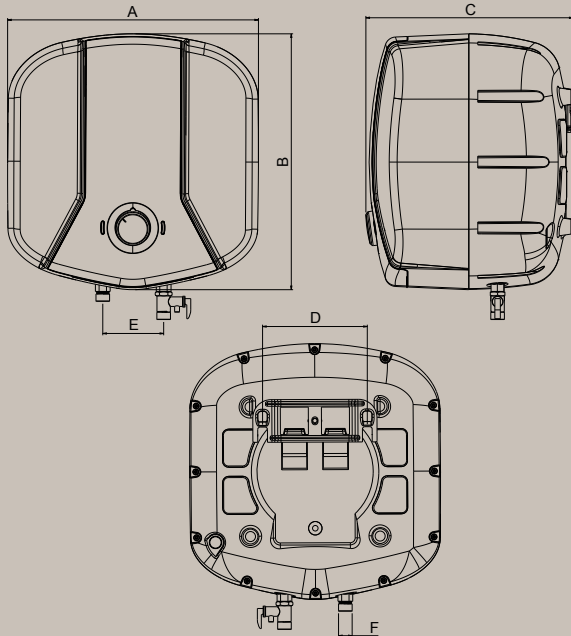

Model	A	B	C	D	E	F
10 L	412 mm	420 mm	280 mm	172 mm	100 mm	21 mm (G 1/2)
15 L	412 mm	420 mm	340 mm	172 mm	100 mm	21 mm (G 1/2)
25 L	466 mm	476 mm	385 mm	68 mm	100 mm	21 mm (G 1/2)



## Features



**Trio Core Heating Element**  
 Highly resistive to corrosion giving it a longer life



**Dual safety feature**  
 With automatic thermal cutoff & thermostat



**Heavy Duty Protective Anode**  
 To help increase life of Storage Tank



**High density CFC free Polyurethane Foam (PUF) insulation**  
 For energy efficiency and to store hot water for longer duration



**Durable Steel tank**  
 Single weld line tank made of ultra thick superior quality steel



**Adjustable Thermostat**  
 All weather temperature setting with maximum temperature of 75 °C



**Water tubes with whirl flow**  
 No immediate direct contact between cold and hot water for faster heating



**Multi functional safety valve**  
 For protection against excessive pressure (> 8 bar), ideal for high rise buildings

\*Warranty on inner tank | \*\*T&C apply

# AMEO

Storage Plastic Water Heater

**+ ANTI-CORROSION TANK + 7 YEARS WARRANTY\* + PRECISE TEMPERATURE CONTROL**



Built with Porco Glass Technology, bring home the long-lasting Ameo water heaters.

Porco Glass coating on the storage tank for longer life

Multi-functional safety valve for protection against excessive pressure

Innovative Whirl Flow Technology for quick heating

Heavy duty protective anode.



PORCO GLASS™  
TECHNOLOGY



PRECISE  
TEMPERATURE  
CONTROL



FREE  
FLEXI PIPES\*\*

Capacity : 10 L, 15 L & 25 L  
 Colors : White Blue & Ivory Red



## Technical dimensions in mm

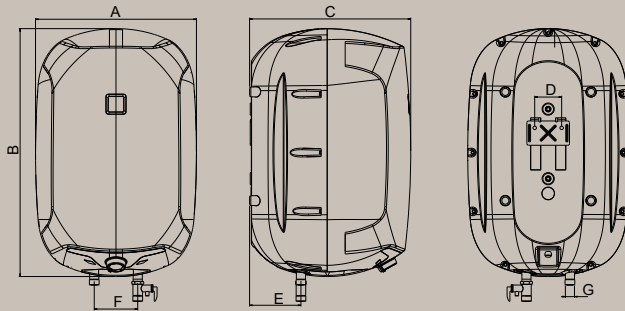

Model	A	B	C	D	E	F	G
10 L	318 mm	462 mm	302 mm	62 mm	79 mm	110 mm	12.7 mm (G 1/2)
15 L	330 mm	485 mm	321 mm	62 mm	94 mm	100 mm	12.7 mm (G 1/2)
25 L	370 mm	570 mm	371 mm	62 mm	118 mm	100 mm	12.7 mm (G 1/2)

\* Note : All dimension are in mm, dimensions tolerances  $\pm 5$ mm.

## Features



**Incoloy 800 heating element with enamel coating**  
 Highly resistive to corrosion giving it a longer life



**Inlet water tubes with whirl flow**  
 No immediate direct contact between cold and hot water for faster heating



**Heavy duty protective anode**  
 To help increase life of Storage Tank



**High density CFC free Polyurethane Foam (PUF) insulation**  
 For energy efficiency and to store hot water for longer duration



**Dual safety feature**  
 With automatic thermal cutoff & thermostat



**Multi functional safety valve**  
 For protection against excessive pressure (> 8 bar), ideal for high rise buildings



**Adjustable Thermostat**  
 All weather temperature setting with maximum temperature of 75 °C



**Durable inner tank**  
 Single weld line tank made of ultra thick superior quality steel

\*Warranty on inner tank | \*\*T&C apply

# PLASH

Storage Metal Water Heater

**+ PORCO GLASS TECHNOLOGY + ANTI-CORROSION TANK + 7 YEARS WARRANTY\***

**NEW**



Bring home the Porco Glass Technology Plash, made with a heavy duty protective anode.

Innovative Whirl Flow Technology for quicker heating

Multi-functional safety valve for protection against excessive pressure

Preset thermal cut-out



PORCO GLASS™  
TECHNOLOGY



PRECISE  
TEMPERATURE  
CONTROL



FREE  
FLEXI PIPES\*\*



Capacity : 10 L, 15 L & 25 L  
 Colors : White & Ivory



## Technical dimensions in mm

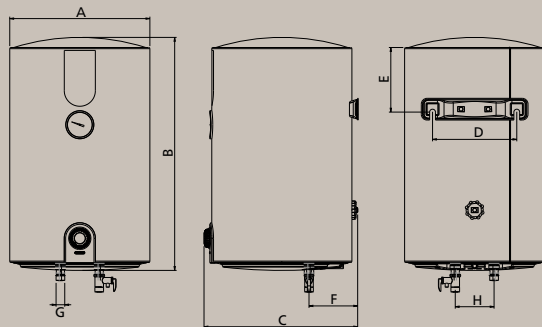

Model	A	B	C	D	E	F	G	H
Plash 10 L	311 mm	445 mm	342 mm	163 mm	162 mm	101 mm	21 mm (G1/2)	100 mm
Plash 15 L	311 mm	540 mm	342 mm	163 mm	162 mm	101 mm	21 mm (G1/2)	100 mm
Plash 25 L	361 mm	600 mm	394 mm	163 mm	166 mm	125 mm	21 mm (G1/2)	100 mm

\* Note : All dimension are in mm, dimensions tolerances ± 5mm.

\*Warranty on inner tank | \*\*T&C apply

## Features



**Trio Core Heating Element**  
 Highly resistive to corrosion giving it a longer life



**Dual safety feature**  
 With automatic thermal cutoff & thermostat



**Heavy Duty Protective Anode**  
 To help increase life of Storage Tank



**High density CFC free Polyurethane Foam (PUF) insulation**  
 For energy efficiency and to store hot water for longer duration



**Durable Steel tank**  
 Single weld line tank made of ultra thick superior quality steel



**Adjustable Thermostat**  
 All weather temperature setting with maximum temperature of 75 °C



**Water tubes with whirl flow**  
 No immediate direct contact between cold and hot water for faster heating



**Multi functional safety valve**  
 For protection against excessive pressure (> 8 bar), ideal for high rise buildings

# AMAZER PLUS

Storage Metal Water Heater

**+ QUICK HEATING TECHNOLOGY + ANTI-CORROSION TANK + 7 YEARS WARRANTY\***



Bring home the tough Amazer Plus, made with a heavy duty protective anode.

Innovative Whirl Flow Technology for quicker heating

Multi-functional safety valve for protection against excessive pressure

Preset thermal cut-out



PORCO GLASS™  
TECHNOLOGY



PRECISE  
TEMPERATURE  
CONTROL



FREE  
FLEXI PIPES\*\*

Capacity : 35 L & 50 L  
 Colors : White



## Technical dimensions in mm

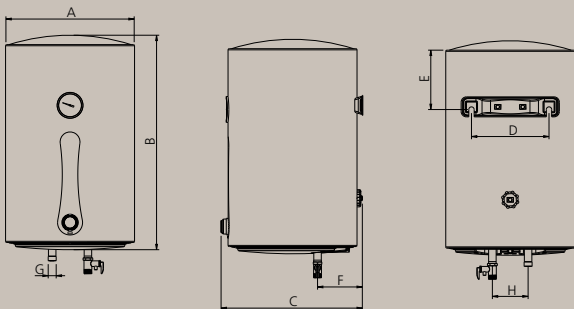

Model	A	B	C	D	E	F	G	H
Amazer Plus 35 L	411 mm	620 mm	444 mm	217 mm	192.5 mm	97 mm	21 mm	100 mm
Amazer Plus 50 L	461 mm	643 mm	494 mm	217 mm	172 mm	97 mm	21 mm	100 mm

## Features



**Incoloy 800 heating element with enamel coating**  
 Highly resistive to corrosion giving it a longer life



**Dual safety feature**  
 With automatic thermal cutoff & thermostat



**Heavy duty protective anode**  
 To help increase life of Storage Tank



**High density CFC free Polyurethane Foam (PUF) insulation**  
 For energy efficiency and to store hot water for longer duration



**Durable inner tank**  
 Single weld line tank made of ultra thick superior quality steel



**Adjustable Thermostat**  
 All weather temperature setting with maximum temperature of 75 °C



**Inlet water tubes with whirl flow**  
 No immediate direct contact between cold and hot water for faster heating



**Multi functional safety valve**  
 For protection against excessive pressure (> 8 bar), ideal for high rise buildings

\*Warranty on inner tank | \*\*T&C apply

# AMAZE

Storage Metal Water Heater

**+ DUAL SAFETY MECHANISM + ANTI-CORROSION TANK + 7 YEARS WARRANTY\***



Designed with a new attractive decal, the tough Amaze is made beautiful.

Innovative Whirl Flow Technology for quicker heating

Multi-functional safety valve for protection against excessive pressure

Preset thermal cut-out



PORCO GLASS™  
TECHNOLOGY



PRECISE  
TEMPERATURE  
CONTROL



FREE  
FLEXI PIPES\*\*

Capacity : 10 L, 15 L, & 25 L  
 Colors : White Blue



## Technical dimensions in mm

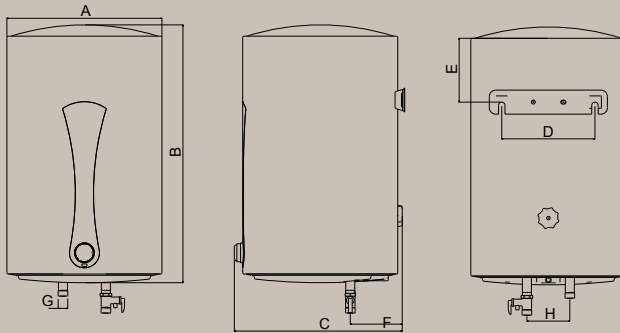

Model	A	B	C	D	E	F	G	H
10 L	311 mm	390 mm	342 mm	217 mm	121 mm	101 mm	12.7 mm (G1/2)	100 mm
15 L	311 mm	492 mm	342 mm	217 mm	124 mm	101 mm	12.7 mm (G1/2)	100 mm
25 L	361 mm	552 mm	394 mm	217 mm	131 mm	125 mm	12.7 mm (G1/2)	100 mm

\* Note : All dimension are in mm, dimensions tolerances  $\pm 5$ mm.

## Features



**Trio Core Heating Element**  
 Highly resistive to corrosion giving it a longer life



**Dual safety feature**  
 With automatic thermal cutoff & thermostat



**Heavy Duty Protective Anode**  
 To help increase life of Storage Tank



**High density CFC free Polyurethane Foam (PUF) insulation**  
 For energy efficiency and to store hot water for longer duration



**Durable Steel tank**  
 Single weld line tank made of ultra thick superior quality steel



**Adjustable Thermostat**  
 All weather temperature setting with maximum temperature of 75 °C



**Water tubes with whirl flow**  
 No immediate direct contact between cold and hot water for faster heating



**Multi functional safety valve**  
 For protection against excessive pressure (> 8 bar), ideal for high rise buildings

\*Warranty on inner tank | \*\*T&C apply

# AMAZER-H

Storage Metal Water Heater

Capacity : 10 L, 15 L & 25 L

Color : White Blue

**+ COMPACT DESIGN + REVERSIBLE OPERATION + 7 YEARS WARRANTY\***

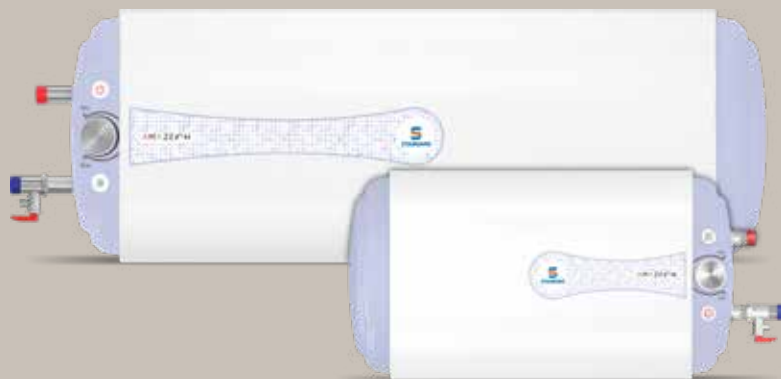

Horizontal water heater is available in both right and left orientation.

Longer life with Incoloy 800 heating element with enamel coating to resist corrosion

Multi-functional safety valve for protection against excessive pressure



PORCO GLASS™  
TECHNOLOGY



PRECISE  
TEMPERATURE  
CONTROL



FREE  
FLEXI PIPES\*\*

# Technical dimensions in mm

Right hand side inlet outlet

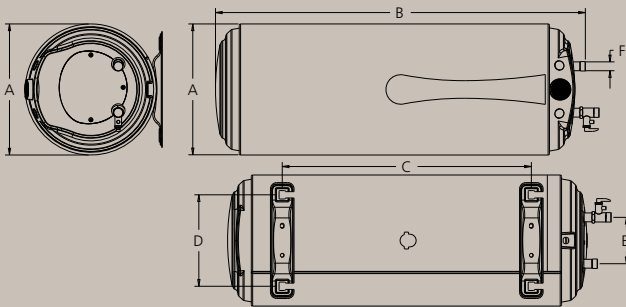

Left hand side inlet outlet

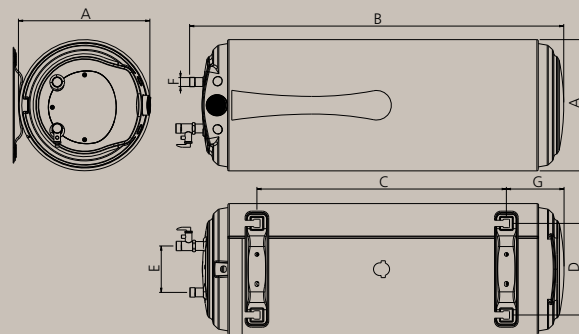

Model	A	B	C	D	E	F	G
10 L	311 mm	473 mm	190 mm	217 mm	110 mm	12.7 mm (G 1/2)	130 mm
15 L	311 mm	602 mm	320 mm	217 mm	110 mm	12.7 mm (G 1/2)	130 mm
25 L	311 mm	875 mm	591 mm	217 mm	110 mm	12.7 mm (G 1/2)	130 mm

\* Note : All dimension are in mm, dimensions tolerances  $\pm 5$ mm.

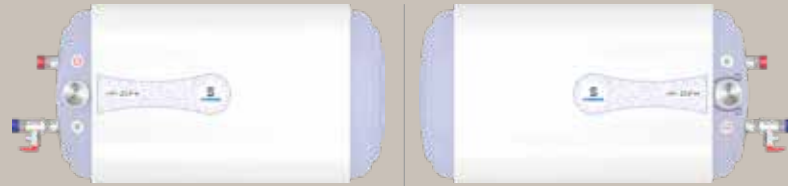

## Features



**Incoloy 800 heating element with enamel coating**  
Highly resistive to corrosion giving it a longer life



**Dual safety feature**  
With automatic thermal cutoff & thermostat



**Heavy duty protective anode**  
To help increase life of Storage Tank



**High density CFC free Polyurethane Foam (PUF) insulation**  
For energy efficiency and to store hot water for longer duration



**Durable inner tank**  
Single weld line tank made of ultra thick superior quality steel



**Adjustable Thermostat**  
All weather temperature setting with maximum temperature of 75 °C



**Inlet Water tube with whirl flow**  
No immediate direct contact between cold and hot water for faster heating



**Multi functional safety valve**  
For protection against excessive pressure (> 8 bar), ideal for high rise buildings

\*Warranty on inner tank | \*\*T&C apply

# LYFT - 6 L

Storage Plastic Water Heater

**+ ANTI-CORROSION TANK + RUST PROOF OUTER BODY + 7 YEARS WARRANTY\***



Lift your bathroom and kitchen's style quotient with the sleek and simple Standard Lyft.

Single weld line tank made of ultra-thick superior cold rolled steel

High Precision Precalibrated Thermostat to help increase life of heating element



PORCO GLASS™  
TECHNOLOGY



FREE  
FLEXI PIPES\*\*



Capacity : 6 L  
 Color : White



## Technical dimensions in mm

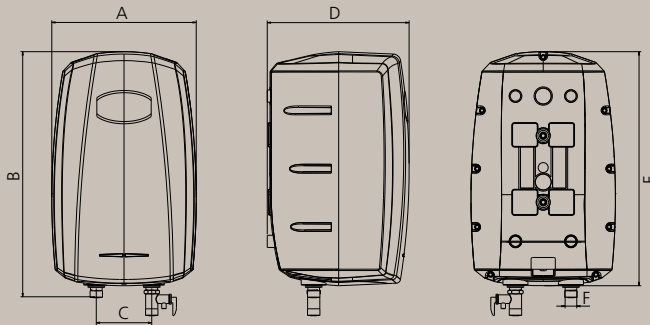

Model	A	B	C	D	E	F
6 L	260 mm	442 mm	100 mm	256 mm	422 mm	12.7 mm (G 1/2)

\* Note : All dimension are in mm, dimensions tolerances  $\pm 5$ mm.

## Features



**Incoloy 800 heating element with enamel coating**  
 Highly resistive to corrosion giving it a longer life



**Heavy duty protective anode**  
 To help increase life of Storage Tank



**Durable inner tank**  
 Single weld line tank made of ultra thick superior quality steel



**Rust Proof Body**  
 High quality ABS outer body



**Dual safety feature**  
 With automatic thermal cutoff & thermostat



**High density CFC free Polyurethane Foam (PUF) insulation**  
 For energy efficiency and to store hot water for longer duration



**High Precision Pre-calibrated Thermostat**  
 To help increase life of heating element



**Multi functional safety valve**  
 For protection against excessive pressure (> 8 bar), ideal for high rise buildings

\*Warranty on inner tank | \*\*T&C apply

# LYFT

Instant Water Heater

**+ CONTEMPORARY DESIGN + RUST PROOF OUTER BODY + 5 YEARS WARRANTY\***



Show off your style quotient with the compact and effective Standard Lyft water heaters.

Innovative compact design for easy installation

Superior 304 L grade stainless steel ultra-thick tank

Rust proof high quality outer body



UNIQUE  
DESIGN



SUPERIOR  
304 L GRADE  
STAINLESS  
STEEL TANK

Capacity : 3 L and 1 L (3 kW & 4.5 kW)  
 Color : White



## Technical dimensions in mm

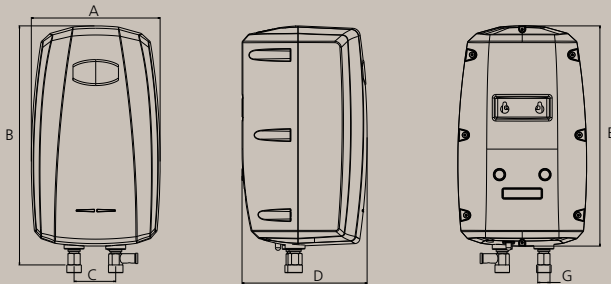

Model	A	B	C	D	E	F
1 L	171 mm	329 mm	64 mm	164 mm	299 mm	12.7 mm (G 1/2)
3 L	198 mm	368 mm	64 mm	193 mm	339 mm	12.7 mm (G 1/2)

\* Note : All dimension are in mm, dimensions tolerances  $\pm 5$ mm.

\*Warranty on inner tank | \*\*T&C apply

## Features



**Stainless Steel Tank**  
 Ultra thick & superior grade SS tank



**High Precision Pre-calibrated Thermostat**  
 To help increase life of heating element



**Rust Proof Body**  
 High quality plastic outer body



**Preset Thermal Cutout**  
 Automatic cut out on high & unsafe temperature



**Safety valve (> 6.5 bar)**  
 Protection against excessive pressure & ideal for high rise building



**Fire Retardant Power Cord**  
 For safety & protection

# CALOR

Instant Water Heater

**+ COMPACT DESIGN + HEAVY DUTY COPPER ELEMENT + 5 YEARS WARRANTY\***

**NEW**



Show off your style quotient with the compact and effective Standard Lyft water heaters.

Innovative compact design for easy installation

Superior 304 L grade stainless steel ultra-thick tank

Rust proof high quality outer body



SUPERIOR  
GRADE  
SS TANK



HIGH  
PRESSURE  
SAFETY  
VALVE



LITRE

Capacity : 3 L & 5 L  
 Color : White



## Technical dimensions in mm

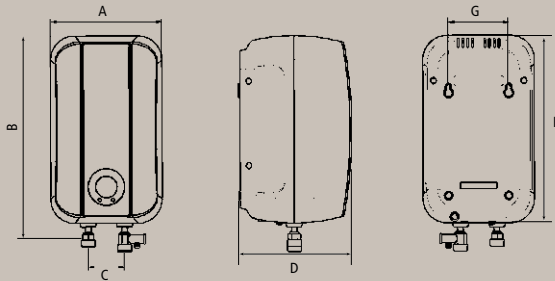

Model	A	B	C	D	E	F	G
Calor 3 L	185 mm	337 mm	60.5 mm	187.5 mm	310 mm	12.5 mm (G 1/2)	100 mm
Calor 5 L	210 mm	430 mm	60.5 mm	210 mm	380 mm	12.5 mm (G 1/2)	120 mm

## Features



**Stainless Steel Tank**  
 Ultra thick & superior grade SS tank



**High Precision Pre-calibrated Thermostat**  
 To help increase life of heating element



**Rust Proof Body**  
 High quality outer body



**Preset Thermal Cutout**  
 Automatic cut out on high & unsafe temperature



**Safety valve (> 6.5 bar)**  
 Protection against excessive pressure & ideal for high rise building



**Fire Retardant Power Cord**  
 For safety & protection

\*Warranty on inner tank | \*\*T&C apply

# ETNA

Immersion Water Heater

**+ MODERN DESIGN + NEON LED INDICATOR + 2 YEARS WARRANTY\***



Show off your style quotient with the compact and effective Standard Etna water heaters.

Modern design with nickel plating on heating element

High temperature resistance Bakelite cover

ISI mark, 3 Pin moulded plug

Flame retardant power cord

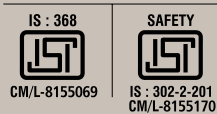

**MADE IN INDIA**



Capacity : 1000 W & 1500 W  
 Color : White



## Technical dimensions in mm

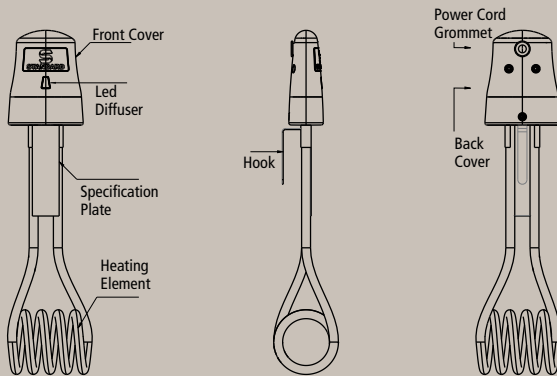

## Features

- 

High temp. Resistance  
Bakelite cover
- 

ISI mark  
3 pin moulded plug
- 

Metal hook for  
Bucket placement
- 

Flame retardant  
Power cord
- 

Nickel plating for  
Corrosion resistance
- 

Heating indicator
- 

Durable large diameter  
Heating element

\*Warranty on inner tank | \*\*T&C apply

## PRODUCT KNOWLEDGE

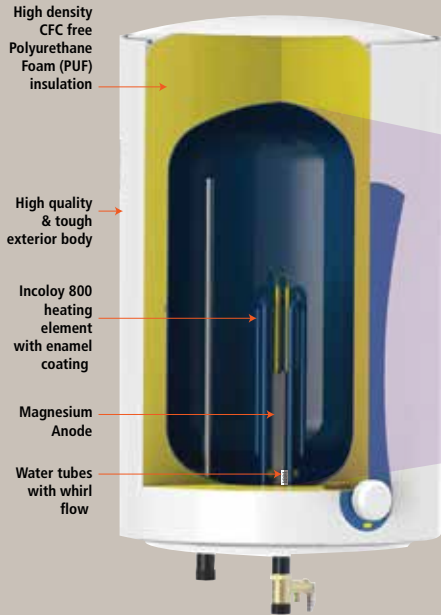

## GUIDE TO WATER HEATER SELECTION

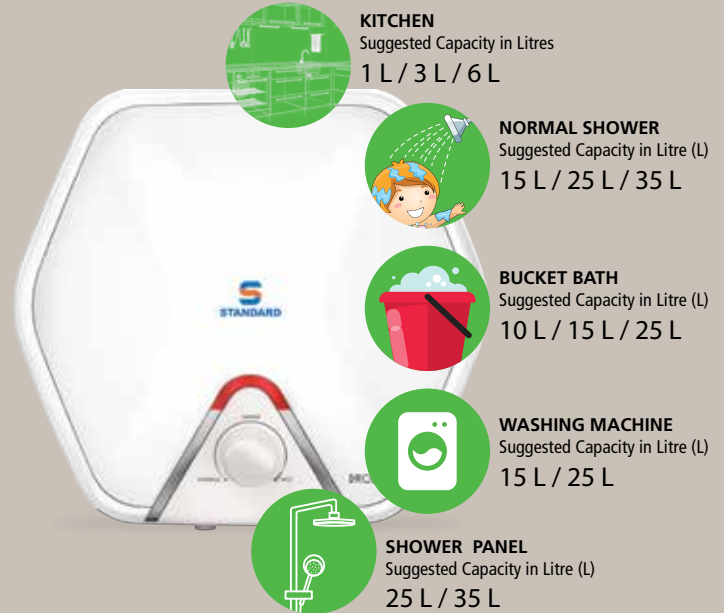



# SPECIFICATION SHEET



Rated Capacity in Litre	DROID-M			GLAZER			AMEO			PLASH			AMAZER PLUS		AMAZE			AMAZER - H			LYFT	LYFT (Instant)			CALOR			
	10 L	15 L	25 L	10 L	15 L	25 L	10 L	15 L	25 L	10 L	15 L	25 L	35 L	50 L	10 L	15 L	25 L	10 L	15 L	25 L	6 L	3 L	1 L	3 L	5 L			
Mounting	Vertical			Vertical			Vertical			Vertical			Vertical		Vertical			Horizontal			Vertical	Vertical			Vertical			
Rated Voltage (V) & frequency (Hz)	230 V / 50 Hz			230 V / 50 Hz			230 V / 50 Hz			230 V / 50 Hz			230 V / 50 Hz		230 V / 50 Hz			230 V / 50 Hz			230 V / 50 Hz	230 V / 50 Hz			230 V / 50 Hz			
Rated Power Input (W)	2000 W			2000 W			2000 W			2000 W			2000 W		2000 W			2000 W			3000 W	3000 W	3000 W	3000 W	3000 W	3000 W	3000 W	
Rated Current (A)	8.7 A			8.7 A			8.7 A			8.7 A			8.7 A		8.7 A			8.7 A			16 A	16 A	24 A	16 A	24 A	16 A	24 A	16 A
Mean Hot Water Output Temp. (°C)	75 °C			75 °C			75 °C			75 °C			75 °C		75 °C			75 °C			75 °C	75 °C			75 °C			
Rated Pressure in MPa	0.8 MPa			0.8 MPa			0.8 MPa			0.8 MPa			0.8 MPa		0.8 MPa			0.8 MPa			0.8 MPa	0.65 MPa			0.65 MPa			
Standing Loss in kWh / 24 h / 45 °C	0.332 kWh	0.381 kWh	0.465 kWh	0.332 kWh	0.381 kWh	0.465 kWh	0.365 kWh	0.419 kWh	0.511 kWh	0.332 kWh	0.381 kWh	0.584 kWh	0.742 kWh	0.419 kWh	0.401 kWh	0.461 kWh	0.562 kWh	0.401 kWh	0.461 kWh	0.562 kWh	0.291 kWh			NA			NA	
Reheating Time in minutes to raise 50 °C (min)	19 min	30 min	60 min	15 min	23 min	43 min	15 min	20 min	35 min	15 min	23 min	43 min	80 min	95 min	15 min	23 min	43 min	15 min	20 min	35 min	11 min			NA			NA	
<b>Weight of water heater (in kg)</b>																												
Water Filled (kg)	19.2 kg	25.15 kg	38.3 kg	21.1 kg	27.7 kg	41.1 kg	18.2 kg	24.3 kg	36.8 kg	21.1 kg	27.7 kg	41.1 kg	52.8 kg	71 kg	21.1 kg	27.7 kg	41.1 kg	19.4 kg	26.6 kg	41 kg	12.4 kg	6.06 kg	6.06 kg	3.2 kg	3.2 kg	5.2 kg	5.2 kg	7.85 kg
Water proof degree	IP X 4			IP X 4			IP X 4			IP X 4			IP X 4		IP X 4			IP X 4			IP X 4	IP X 4			IP X 4			
Class of appliance	Class I			Class I			Class I			Class I			Class I		Class I			Class I			Class I	Class I			Class I			
Star Rating	5 star			5 star			4 Star			5 Star			4 star		4star			4 star			4 Star	NA			NA			
Product Warranty	2 years			2 years			2 years			2 years			2 years		2 years			2 years			2 years	2 years			2 years			
Heating Element Warranty	4 years			4 years			4 years			4 years			4 years		4 years			4years			4 years	2 years			2 years			
Tank Warranty	7 years			7 years			7 years			7 years			7 years		7 years			7 years			7 years	5 years			5 years			